

Inverted microscopes

- > Reflected light microscopy is the choice for imaging opaque samples. The sample is illuminated from above through the objective. Because light is unable to pass through opaque samples, it is directed on the surface and returned to the objective by reflection.
- > Most common samples are : metals, plastic materials, wood, silicon, ceramics, rocks, etc.

OBSERVATION

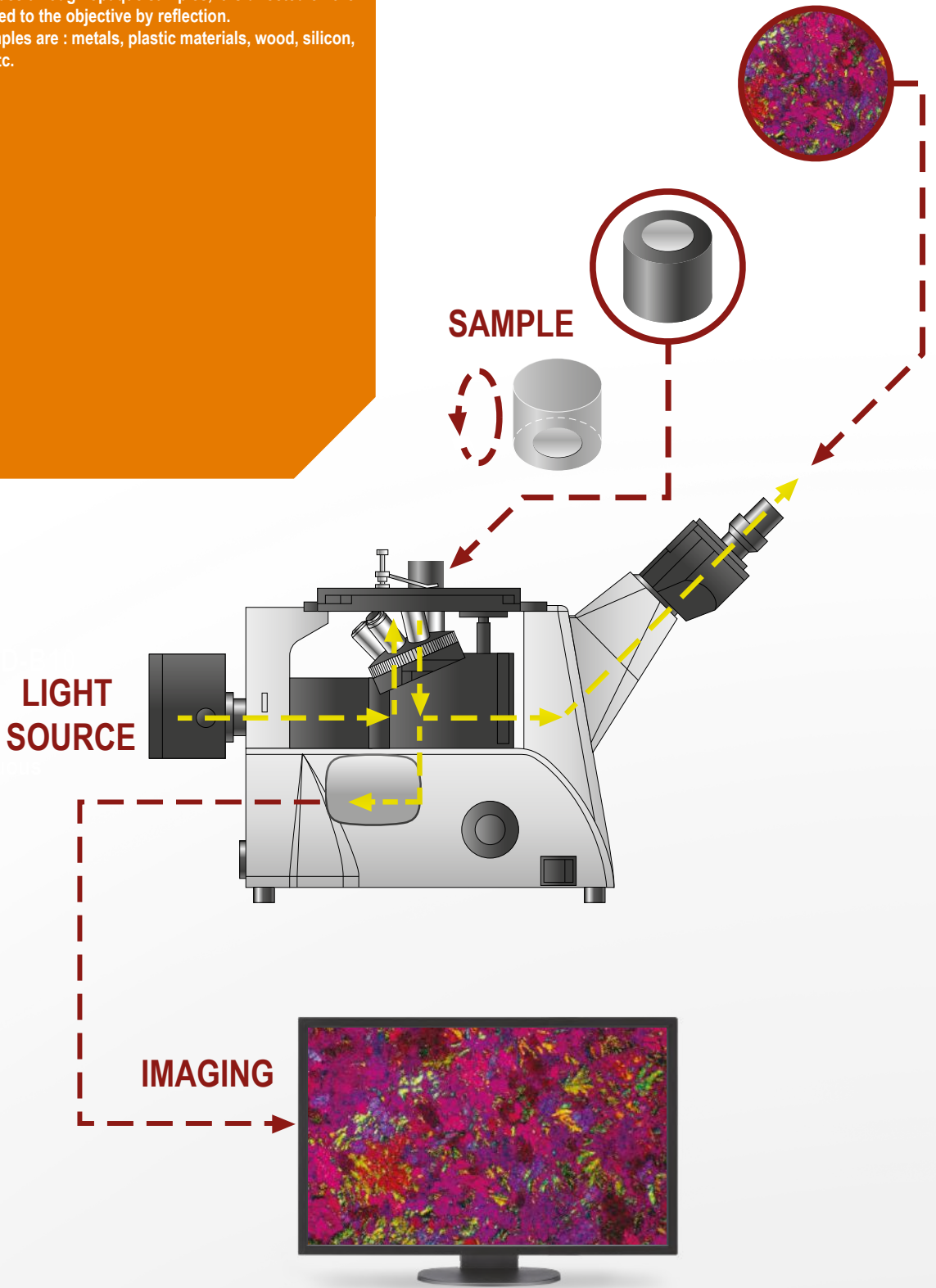

- > Inverted reflected light microscope has two eyepieces, normally 10x magnification, and, in most cases, a tube head dedicated for using a camera system, this connection can be on the viewing tube or on the microscope body.
- > The nosepiece is capable of holding from four to six objectives, these can be recognized by the Epi tag on their external cover.
- > Mechanical stage sample holder can be moved in the XY axis, while the nosepiece can be moved up and down through coarse and fine focusing mechanism. In certain configurations these movements can be automated by using motorized stage systems.

- > The illumination system is built-in with dedicate lamp housing, the generated light passes through a vertical illuminator to the nosepiece and then deflected to the viewing tube head.
- > The sample is placed upside down on the stage with the surface to be observed facing the objective.
- > The advantage of these microscope type is that samples can have bigger shape with only one flat surface.
- > Several techniques are commonly used : Brightfield, Darkfield, Polarized light and Differential Interference Contrast (DIC) and fluorescence.



IM 500 DIC



Model	IM 500 DIC
Optical system	CCIS
Total magnification	50x - 100x - 200x - 500x
Eyepiece	WF 10x (ø22mm)
Plan achromatic objectives long working distance	PL L 5x/0.12BD WD=9.70mm (for DIC observation)
	PL L 10x/0.25BD WD=9.30mm (for DIC observation)
	PL L 20x/0.40BD WD=7.23mm (for DIC observation)
	PL L 50x/0.70BD WD=2.50mm
DIC slider	DIC slider for DIC objectives 5x-10x-20x
Head	Trinocular
	Inclination of 45°
	Interpupillary distance 53mm-75mm
	Diopter adjustable ±5
Nosepiece	Quintuple back ball bearing inner locating
Stage	Double layer mechanical with glass insert, overall size 242x220mm
	Metal platen with inner hole ø21mm
	Coaxial motion 30x30mm
Focusing System	Coaxial coarse/fine focus system, minimum division of fine focusing 2µm
	Tensional adjustable with upper stop
Reflected illumination	Illumination with integrated field diaphragm and aperture diaphragm
	12V 50W halogen lamp with brightness control
Polarization	360° rotatable polarizer
Analyzer	360° rotatable analyzer
Filter	Yellow for reflected light
	Blue for reflected light
	Green for reflected light
	Frosted glass filter for reflected light
Contrast techniques	Brightfield: Yes
	Darkfield: Yes
	DIC: Yes
	POL Contrast: Yes
Power supply	230V ±10% - 50/60Hz -1Ph - 30W
Dimensions	560x480x640mm
Weight	19kg

Optional accessories	
Model	Description
IM E-500-01	Eyepiece WF10x (ø22mm) crosshair 0.1mm/Div
IM O-500DIC-21	Long working distance objective PL L 40x/0.60BD WD=3.00mm
IM O-500DIC-22	Long working distance objective PL L 60x/0.75BD WD=1.90mm
IM O-500DIC-23	Long working distance objective PL L 80x/0.80BD WD=0.80mm
IM O-500DIC-24	Long working distance objective PL L 100x/0.85BD WD=0.40mm
IM CA-500-91	Camera adapter 1x
IM CA-500-92	Camera adapter 0.5x with dividing 0.1mm/Div

IM 500 BD



Model	IM 500 BD
Optical system	CCIS
Total magnification	50x - 100x - 200x - 500x
Eyepiece	WF 10x (ø22mm)
Plan achromatic objectives long working distance	PL L 5x/0.12BD WD=9.70mm
	PL L 10x/0.25BD WD=9.30mm
	PL L 20x/0.40BD WD=7.23mm
	PL L 50x/0.70BD WD=2.50mm
Head	Trinocular
	Inclination of 45°
	Interpupillary distance 53mm-75mm
	Diopter adjustable ±5
Nosepiece	Quintuple back ball bearing inner locating
Stage	Double layer mechanical with glass insert, overall size 242x220mm
	Metal platen with inner hole ø21mm
	Coaxial motion 30x30mm
Focusing System	Coaxial coarse/fine focus system, minimum division of fine focusing 2µm
	Tensional adjustable with upper stop
Reflected illumination	Illumination with integrated field diaphragm and aperture diaphragm 12V 50W halogen lamp with brightness control
Polarization	360° rotatable polarizer
Analyzer	360° rotatable analyzer
Filter	Yellow for reflected light
	Blue for reflected light
	Green for reflected light
	Frosted glass filter for reflected light
Contrast techniques	Brightfield: Yes
	Darkfield: Yes
	DIC: Not available
	POL Contrast: Yes
Power supply	230V ±10% - 50/60Hz -1Ph - 30W
Dimensions	560x480x640mm
Weight	18kg

Optional accessories	
Model	Description
IM E-500-01	Eyeiece WF10x (ø22mm) crosshair 0.1mm/Div
IM O-500BD-21	Long working distance objective PL L 40x/0.60BD WD=3.00mm
IM O-500BD-22	Long working distance objective PL L 60x/0.75BD WD=1.90mm
IM O-500BD-23	Long working distance objective PL L 80x/0.80BD WD=0.80mm
IM O-500BD-24	Long working distance objective PL L 100x/0.85BD WD=0.40mm
IM CA-500-91	Camera adapter 1x
IM CA-500-92	Camera adapter 0.5x with dividing 0.1mm/Div

IM 500



Model	IM 500
Optical system	CCIS
Total magnification	100x - 200x - 500x - 1000x
Eyepiece	WF 10x (ø22mm)
Plan achromatic objectives long working distance	PL L 10x/0.25 WD=9.20mm
	PL L 20x/0.40 WD=8.80mm
	PL L 50x/0.70 WD=3.68mm
	PL L 100x/0.85 WD=0.40mm
Head	Trinocular
	Inclination of 45°
	Interpupillary distance 53mm-75mm
	Diopter adjustable ±5
Nosepiece	Quintuple back ball bearing inner locating
Stage	Double layer mechanical with glass insert, overall size 242x220mm
	Metal platen with inner hole ø21mm
	Coaxial motion 30x30mm
Focusing System	Coaxial coarse/fine focus system, minimum division of fine focusing 2µm
	Tensional adjustable with upper stop
Reflected illumination	Illumination with integrated field diaphragm and aperture diaphragm
	6V 30W halogen lamp with brightness control
Polarization	360° rotatable polarizer
Analyzer	360° rotatable analyzer
Filter	Yellow for reflected light
	Blue for reflected light
	Green for reflected light
	Frosted glass filter for reflected light
Contrast techniques	Brightfield: Yes
	Darkfield: Not available
	DIC: Not available
	POL Contrast: Yes
Power supply	230V ±10% - 50/60Hz -1Ph - 30W
Dimensions	560x480x640mm
Weight	16kg

Optional accessories	
Model	Description
IM E-500-01	Eyepiece WF10x (ø22mm) crosshair 0.1mm/Div
IM O-500-21	Long working distance objective PL L 40x/0.60 WD=3.68mm
IM O-500-22	Long working distance objective PL L 60x/0.70 WD=3.18mm
IM O-500-23	Long working distance objective PL L 80x/0.80 WD=1.28mm
IM CA-500-91	Camera adapter 1x
IM CA-500-92	Camera adapter 0.5x with dividing 0.1mm/Div

COMPONENTS DIAGRAM

IM 500 Series

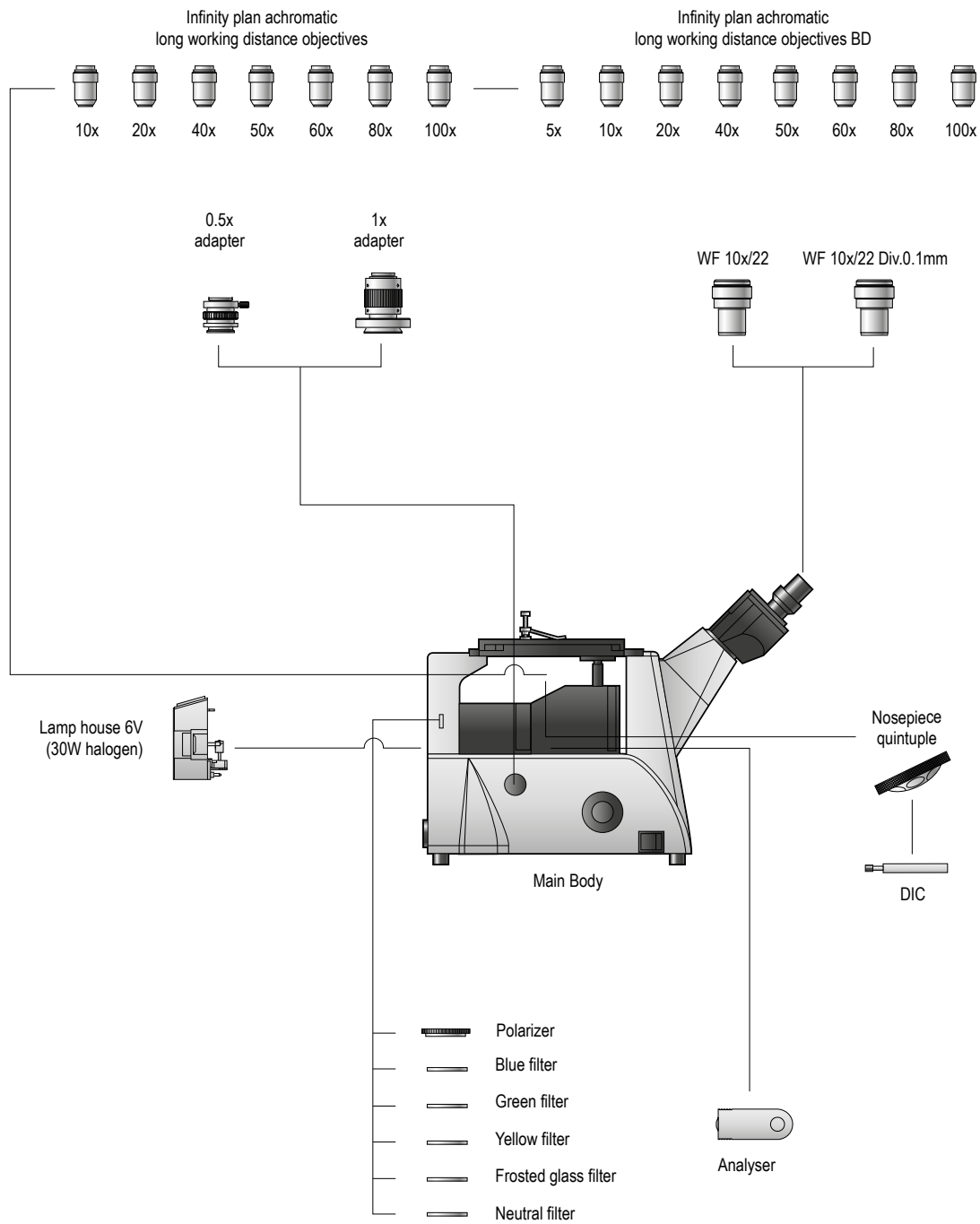

IM 200



Model	IM 200
Optical system	CCIS
Total magnification	40x - 100x - 200x - 400x
Eyepiece	WF 10x (ø18mm)
	WF 10x (ø18mm) with crosshair 0.1mm/Div.
Plan achromatic objectives	PL 4x/0.10 WD=25.00mm
	PL 10x/0.25 WD=11.00mm
	PL 20x/0.40 WD=9.00mm
	PL 40x/0.60 WD=3.80mm
Head	Trinocular
	Inclination of 45°
	Interpupillary distance 55mm-75mm
	Diopter adjustable ±5
Nosepiece	Quadruple back ball bearing inner locating
Stage	Double layer mechanical with glass insert, overall size 172x172mm
	Coaxial motion 30x30mm
Focusing System	Coaxial coarse/fine focus system, minimum division of fine focusing 2µm
	Tensional adjustable with upper stop
Reflected illumination	Epi-illumination with field Iris diaphragm and aperture Iris diaphragm
	6V 30W halogen lamp with brightness control
Polarization	Internal polarizer
Analyzer	360° rotatable analyzer
Filter	Yellow for reflected light
	Blue for reflected light
	Green for reflected light
Contrast techniques	Brightfield: Yes
	Darkfield: Not available
	DIC: Not available
	POL Contrast: Yes
Power supply	230V ±10% - 50/60Hz - 1Ph - 30W
Dimensions	480x400x360mm
Weight	9kg

Optional accessories	
Model	Description
IM O-200-22	Objective PL 100x/0.85 WD=0.40mm
IM CA-200-91	Camera adapter 0.5x

COMPONENTS DIAGRAM

IM 200

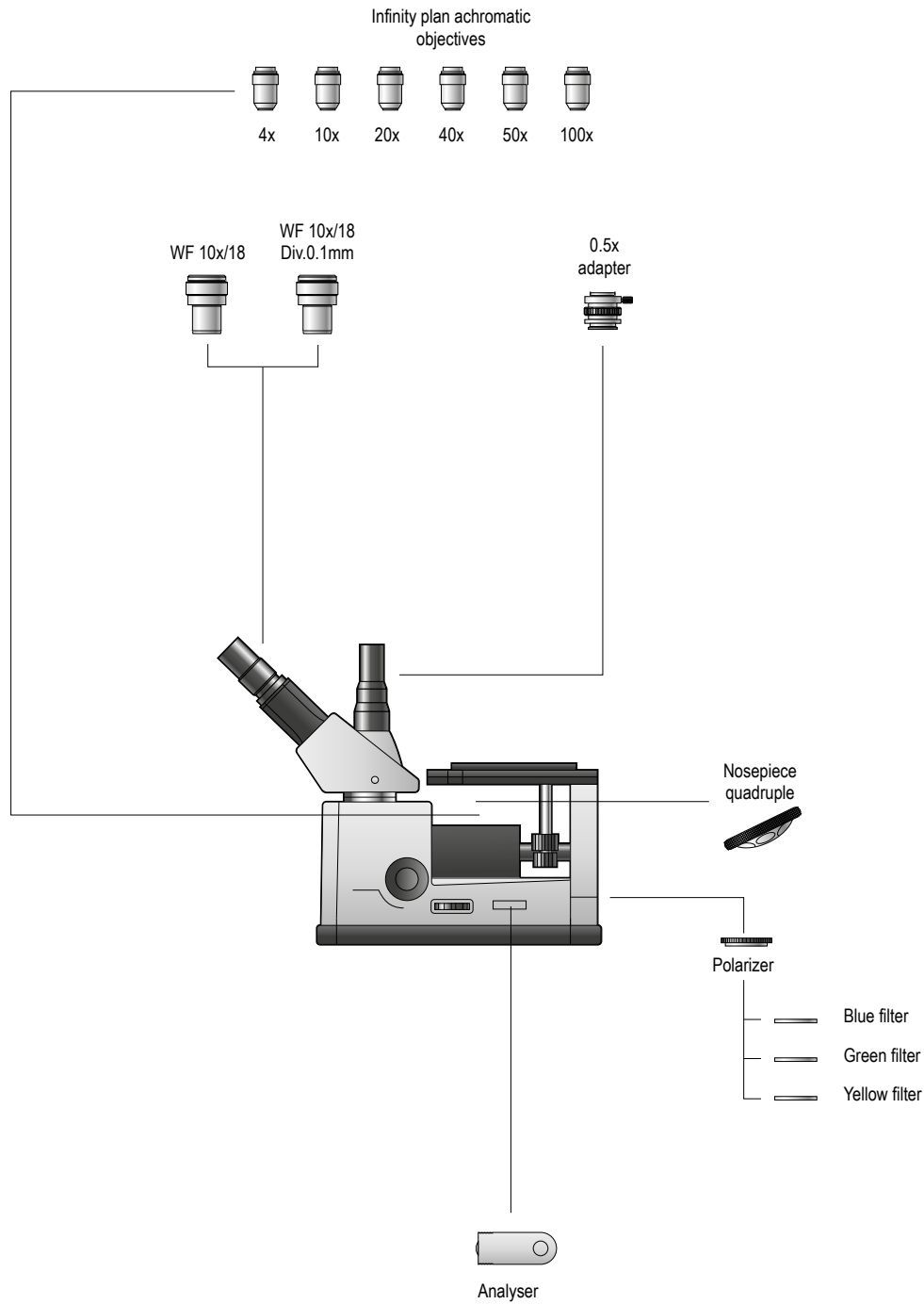

X-PRO 500

- > Following the philosophy of technology research and continuous development, echoLAB realizes in partnership with PRIOR SCIENTIFIC, leader in microscope automation, a new microscope system with motorized stage.
- > X-PRO 500 motorized system for inverted material science microscopes:
 - IM 500DIC
 - IM 500BD
 - IM 500

Joystick

- > Three axis joysticks for X,Y and Z manual control, available with stage systems to provide fast and responsive control
- > Two programmable Hot Keys for a variety of system controls.

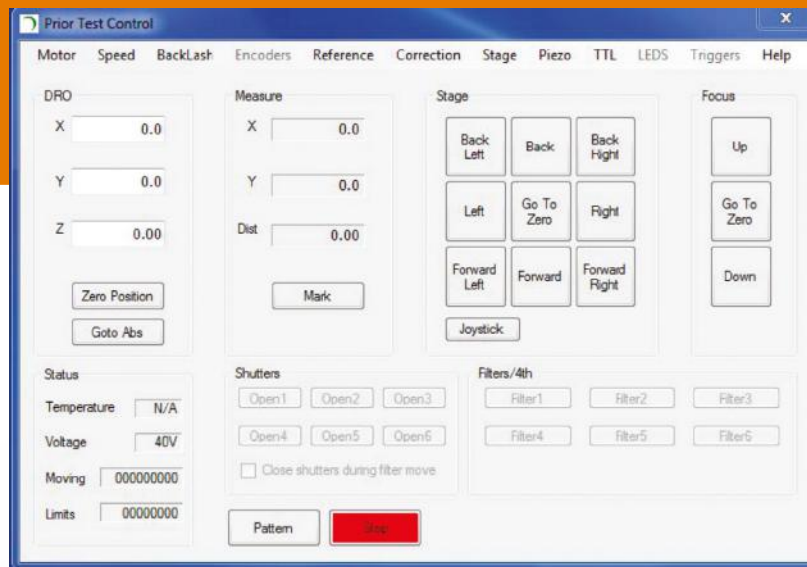

Software

- > X-PRO controllers are supplied with software development toolkit which includes comprehensive dll, VB demo program and a full complement of ASCII commands. The developer can use either the USB or the RS232 serial port for software communications.
- > Through software is possible to move the stage and focusing directly from PC by two methods:
 - 1) Text file editing, with all commands for stage and focus.
 - 2) Using software like a joystick or inserting coordinates X,Y and Z for sample movement in the desired position.

Focus drive X

- > No twist cable connection
- > 0.002µm minimum step size
- > Easy to install
- > Up to 20Rev/s top speed. Simple easy to fit Z solutions for most microscopes
- > The motorized focus control provides step sizes as small as 0.002µm, giving excellent resolution for precise and repeatable focusing in the Z-axis. For large movements when speed is required, the focus motor can be driven at speeds of up to 20 revolutions per second
- > Drive with rotating cable system, designed to prevent cable twisting.



X-PRO 500

Motorized stage

> FX-PROES107 offers high level of flexibility. It is the perfect choice for researchers who require a precision motorized stage.

Features:

The unique S curve acceleration algorithm allows fast, smooth positioning without vibration, reducing disruption to samples. Controllable via joystick, RS232 or USB

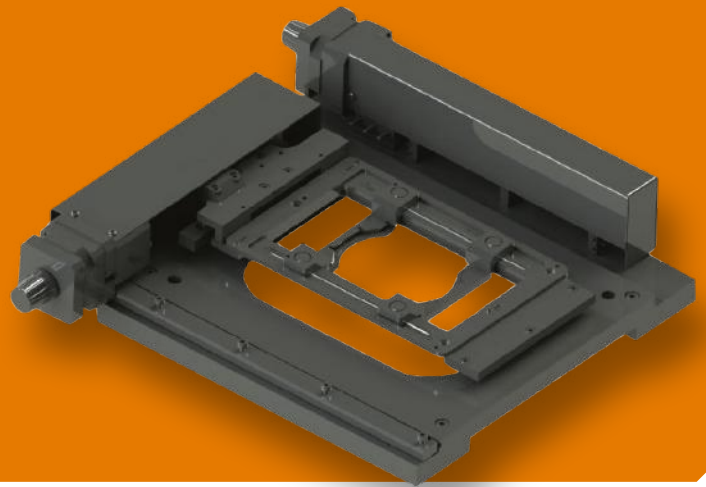

Travel Range	115x77mm
Repeatability	±5µm
Resolution	1µm
Linear slides	3mm ball bearing
Drive mechanism	Anti-backlash precision lead screw
Limit switches	X and Y standard, semi adjustable

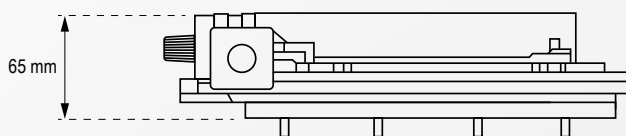
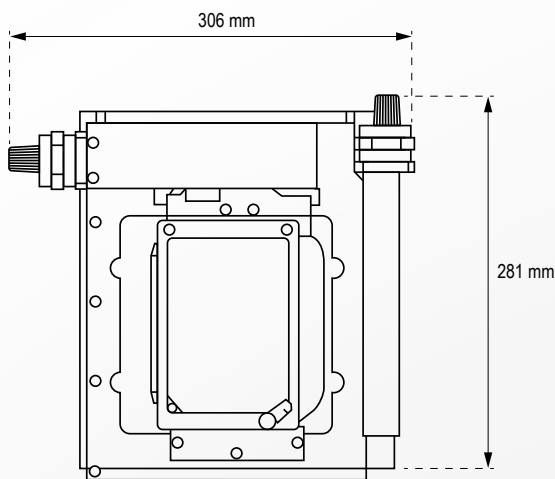

Sample holders

Wide range of sample holders available for one or more samples per time:

